

CARATTERISTICHE TECNICHE
(TECHNICAL FEATURES)
ARDOR SVM 31

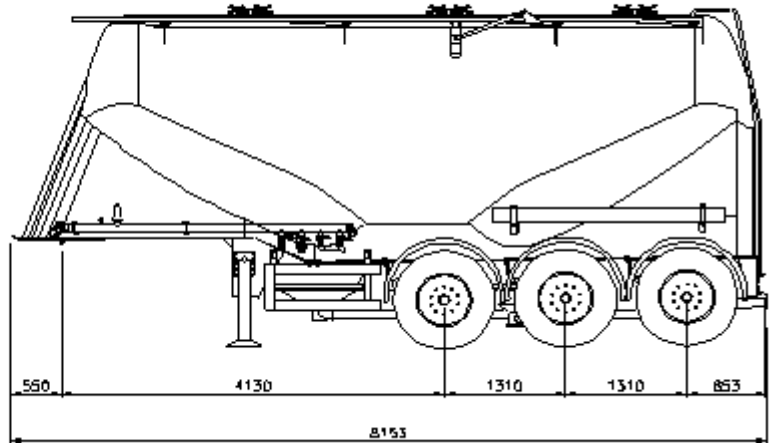
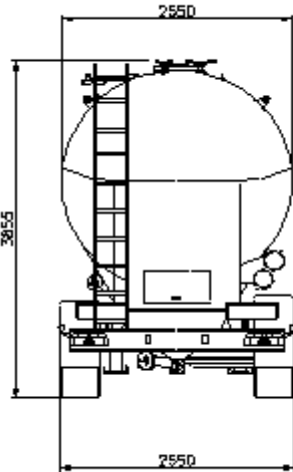

Lunghezza Totale **8153 mm**
(Total Length)

Passo (Distanza perno ralla 1° asse) **4130 mm**
(Distance King-Pin to 1th axle)

Distanza Tra Gli assi **1310 mm**
(Distance between axles)

Larghezza Massima **2550 mm**
(Maximum Width)

Altezza **3855 mm**
(Height)

TARA..... **4320 kg**
(Tare weight)

P.T.T (Massa Totale a Terra)..... **40000 kg**
(G.V.M. Total weight))

Portata Utile **35680 kg**
(Payload))

Volume **31,00 mc**
(Volume)

Pressione max di esercizio **2 bar**
(Service Pressure)

N.B. - le misure riportate sono indicative
- le caratteristiche tecniche possono subire variazioni